

# Fiber Optic GaAlAs High Speed LED

## Types OPF392A, OPF392B, OPF392C, OPF392D

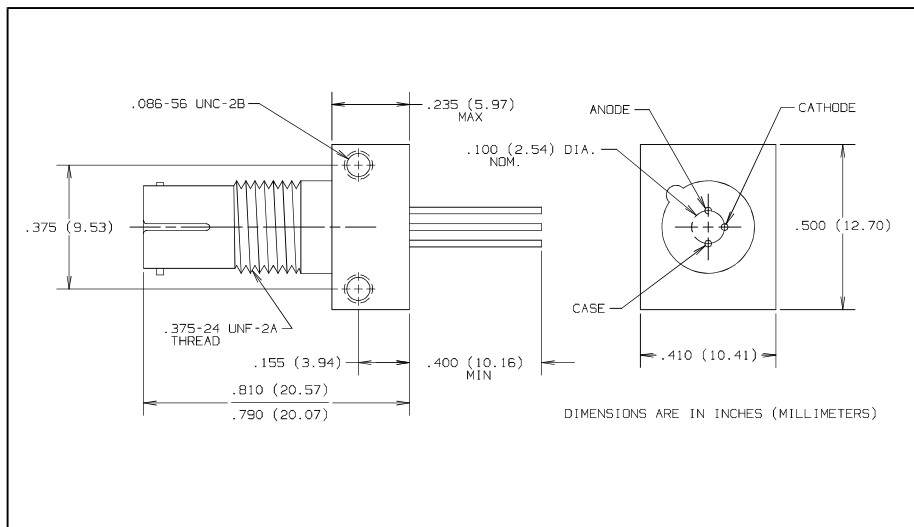
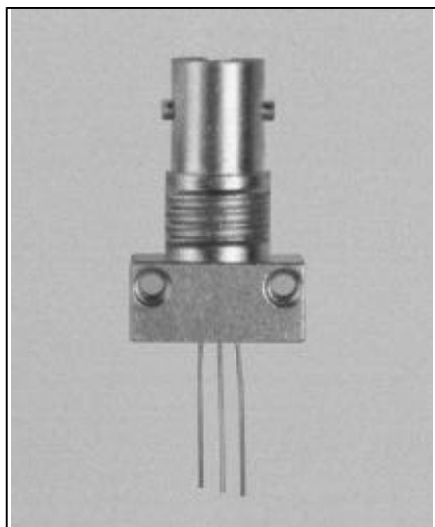

### Features

- Component pre-mounted and ready to use
- Pre-tested with fiber to assure performance
- Popular ST style receptacle
- High Speed
- Electrically isolated from case

### Description

The OPF392 series LED consists of a low cost plastic cap LED, pre-mounted and aligned in an ST receptacle. This configuration is designed for PC board or panel mounting. Includes lock washer and jam nut, two 2-56 screws, and a dust cap.

The LED's are designed to interface with multimode optical fibers from 50/125 to 200/300 microns.

\*ST is a registered trademark of AT&T.

### Absolute Maximum Ratings ( $T_A = 25^\circ\text{C}$ unless otherwise noted)

Reverse Voltage	1.0 V
Continuous Forward Current	100 mA <sup>(4)</sup>
Storage Temperature Range	$-55^\circ\text{C}$ to $+100^\circ\text{C}$
Operating Temperature Range	$-40^\circ\text{C}$ to $+85^\circ\text{C}$
Lead Soldering Temperature [1/16 inch (1.6 mm) from case for 5 sec. with soldering iron]	$240^\circ\text{C}$ <sup>(1)</sup>

#### Notes:

- (1) RMA flux is recommended. Duration can be extended to 10 sec. max when flow soldering.
- (2) Graded index fiber, 50  $\mu\text{m}$  core, N.A. = 0.20.
- (3) To convert radiant power output to dBm, use the following expression  $\text{dBm} = 10 \log (\mu\text{W}/1000)$ .
- (4) Derate linearly @ 1.0 mA/ $^\circ\text{C}$  above  $25^\circ\text{C}$ .
- (5) Prebias @ 5 mA current.

### LED Burn-in

**All LED's are subject to 100% burn-in testing. Test conditions are 96 hours at 100 mA continuous current in  $25^\circ\text{C}$  ambient.**

### TYPICAL COUPLED POWER into OPTICAL FIBER

Typical Coupled Power $I_F = 100\text{ mA @ }25^\circ\text{C}$						
Fiber	Refractive Index	N.A.	OPF392D	OPF392C	OPF392B	OPF392A
50/125 $\mu\text{m}$	Graded	0.20	7.5 $\mu\text{W}$	12.5 $\mu\text{W}$	18 $\mu\text{W}$	25 $\mu\text{W}$
62.5/125 $\mu\text{m}$	Graded	0.28	27 $\mu\text{W}$	35 $\mu\text{W}$	45 $\mu\text{W}$	75 $\mu\text{W}$
100/140 $\mu\text{m}$	Graded	0.29	58 $\mu\text{W}$	85 $\mu\text{W}$	115 $\mu\text{W}$	170 $\mu\text{W}$
200/300 $\mu\text{m}^*$	Step	0.41	290 $\mu\text{W}$	450 $\mu\text{W}$	545 $\mu\text{W}$	650 $\mu\text{W}$

\*PCS - Plastic Clad Silica

# Types OPF392A, OPF392B, OPF392C, OPF392D

Electrical Characteristics ( $T_A = 25^\circ\text{C}$  unless otherwise noted)

SYMBOL	PARAMETER	MIN	TYP	MAX	UNITS	TEST CONDITIONS	
$P_O$	Radiant Power Output	OPF392D	5.0	7.5		$\mu\text{W}$	$I_F = 100\text{ mA}^{(2)}$
		OPF392C	10.0	12.5			
		OPF392B	15.0	18.0			
		OPF392A	20.0	25.0			
$V_F$	Forward Voltage		1.5	2.0	V	$I_F = 100\text{ mA}$	
$\lambda_p$	Peak Output Wavelength	830	850	870	nm	$I_F = 50\text{ mA}$	
B	Spectral Bandwidth Between Half Power Points		35		nm	$I_F = 50\text{ mA}$	
$t_r$	Output Rise Time		4.5	6.0	ns	$I_F = 100\text{ mA}, 10\%-90\%^{(5)}$	
$t_f$	Output Fall Time		4.5	6.0	ns	$I_F = 100\text{ mA}, 90\%-10\%^{(5)}$	

## Typical Performance Curves

Relative Coupled Power vs. Forward Current

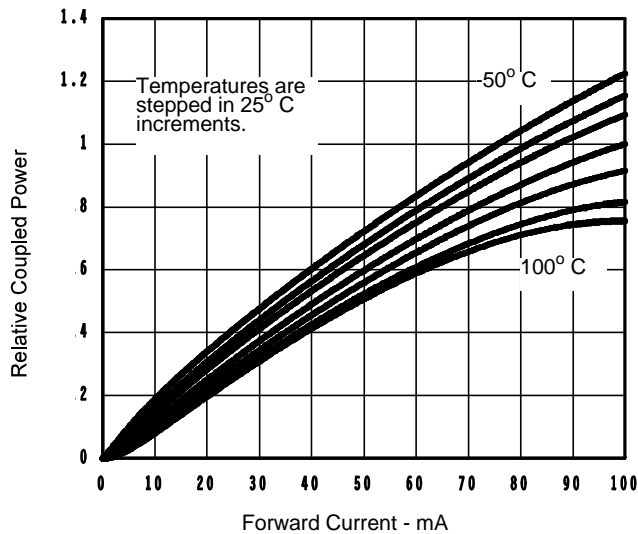

Forward Voltage vs. Forward Current

